

Unicla[®] hDrive[™]

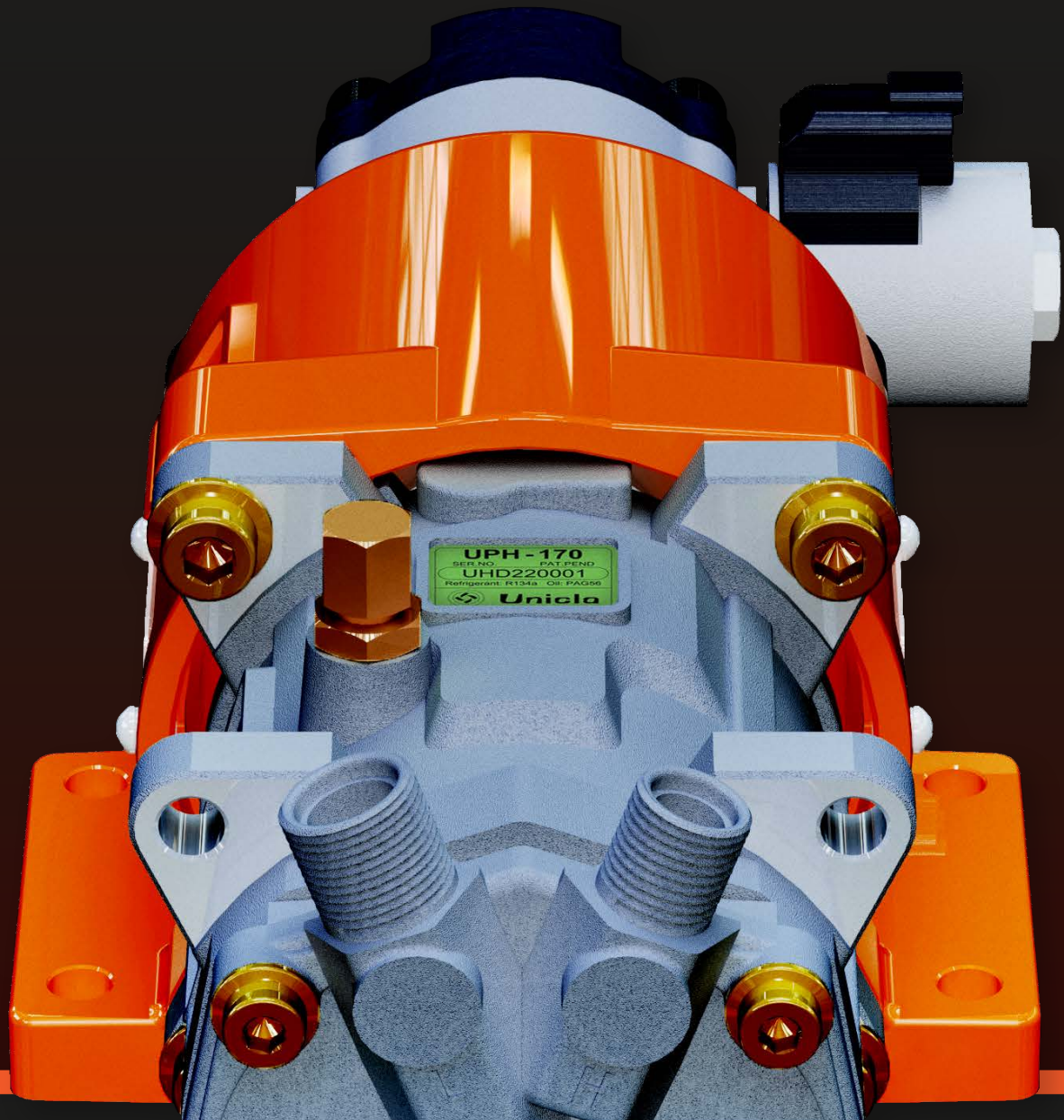

Table of Contents

| | |
|------------------------------------------------|----|
| Look no further..... | 2 |
| Engineered for freedom..... | 3 |
| Greater than the sum of its parts..... | 4 |
| Unicla Hydraulic Drive Assembly Schematic..... | 5 |
| Hydraulic Motor Assembly Schematic..... | 7 |
| Plug and Play..... | 10 |
| The Ten-Point plan..... | 11 |
| The Whole Family is Here..... | 13 |

Copyright © 2024 All rights reserved
No part of this document shall be reproduced in whole or in part without the permission of Unicla International Limited. This includes reproduction or copies in any form or by any means including photocopying, printing or electronic media.

IMPORTANT DISCLAIMER
This is a guideline document containing professional information using representative graphs, charts and tables. Manufacturers' specifications must be consulted for specific guidelines and performance data. Unicla published data, specific to all models, is available in promotional literature and from Unicla International Limited on request or through your Unicla supplier. Unicla International Ltd expressly disclaims all and any liability and responsibility to any person or business as a result of any actions taken on the basis of information in this publication.

Note: Specifications and dimensions are subject to change. Please contact our sales team for confirmation and updates.

hDrive hydraulic compressor family. Look no further.

At Unicla, problem solving is in our DNA. Since the 1960's, we've been engineering real-world solutions for real-world problems. Our Gen III hDrive compressor family offers a plug-and-play solution for every heavy-equipment asset AC compressor problem. It's exactly what you've been looking for.



Scan the QR Code
or visit our website at
unicla.hk/products/hdrive
for more information



Engineered for freedom.

Universal... in any universe.

The Unicla Gen III hDrive compressors are designed for universal application and freedom of installation. The range can be driven by any 11-15 cc hydraulic motor with a standard SAE twin-bolt, A-type mounting configuration, and 5/8" nine-spline shaft.

Featuring four sturdy mounting points integral to the coupler housing, the hydraulic drive compressor assembly allows engineers and technicians the flexibility to locate the unit almost anywhere. The range offers multi-refrigerant compatibility including R134a, R404A, R452A, R1234yf and R513A refrigerants, and boasts three compressor capacity options - UPH150 (5 kW), UPH170 (7 kW), UPH200 (10 kW). Further freedom is achieved through the choice of Vertical or Horizontal #8/#10 O-ring rear caps.

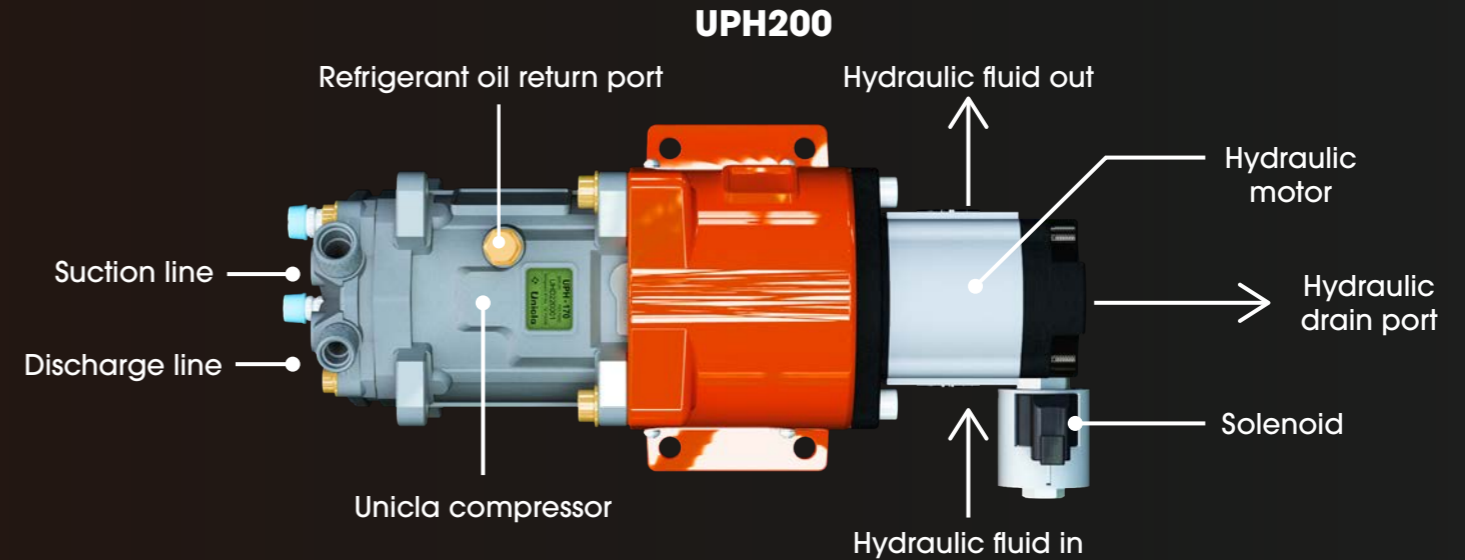
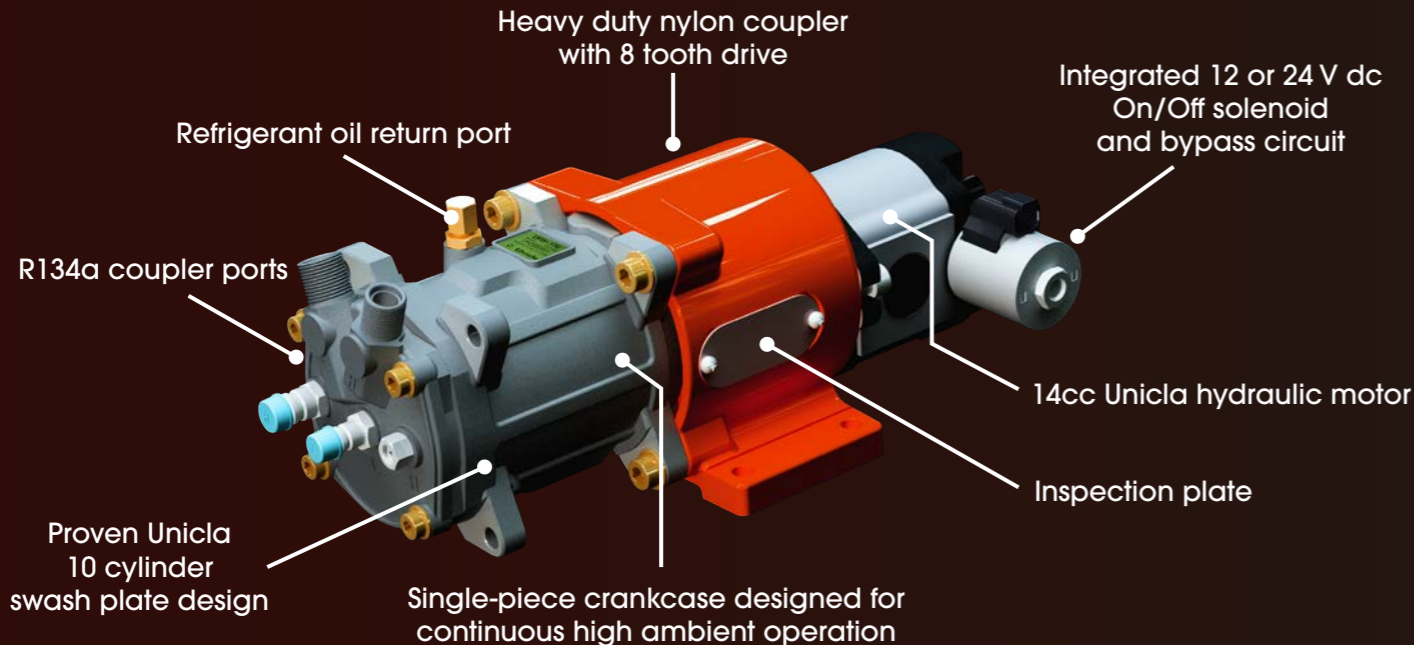

Greater than the sum of its parts.

The package that packs a punch.

With the enviable power to provide full compressor output while your asset is idling, the Gen III hDrive compressor assemblies offer a complete, compact and easy-to-fit solution. The Unicla compressor, drive coupling, housing, and hydraulic motor come pre-assembled and ready to install. The rear cylinder head on all models features low and high-side service ports, and a high-pressure relief valve.

The Unicla hDrive compressor body includes a 7/16" UNF male flare refrigerant oil return port. The hydraulic motor can be optioned without a solenoid, or with the choice of a 12 or 24 V dc solenoid. Both solenoid options are supplied with a 2-pin Deutsch connector and a 2-pin male Deutsch plug with 1 metre of pre-wired harness.

Unicla hDrive

Assembly Schematic

The following diagrams show assembly dimensions for the UPH150, UPH170 and UPH200 models.

Note: the rear caps shown in the schematics are typical of a Vertical O-ring configuration. The rear cap shown in the image below is typical of a Horizontal O-ring configuration.

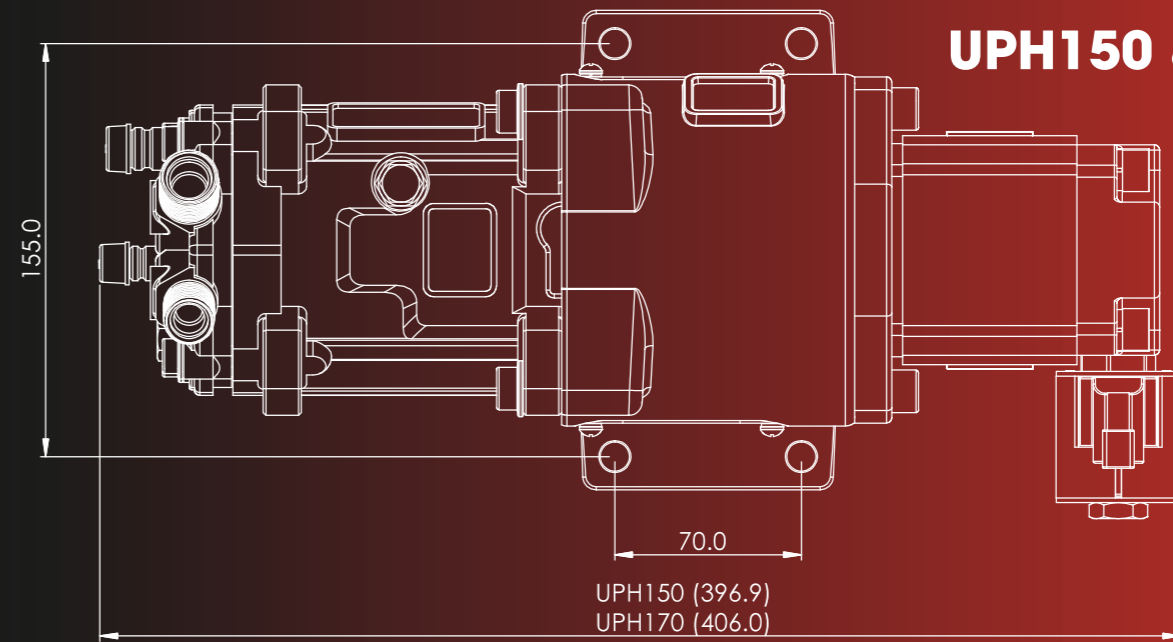
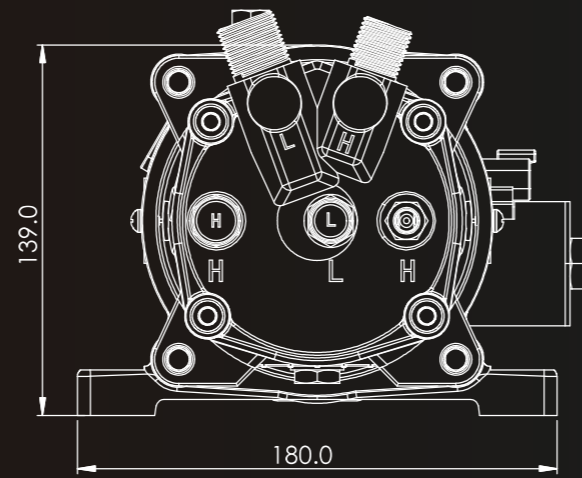
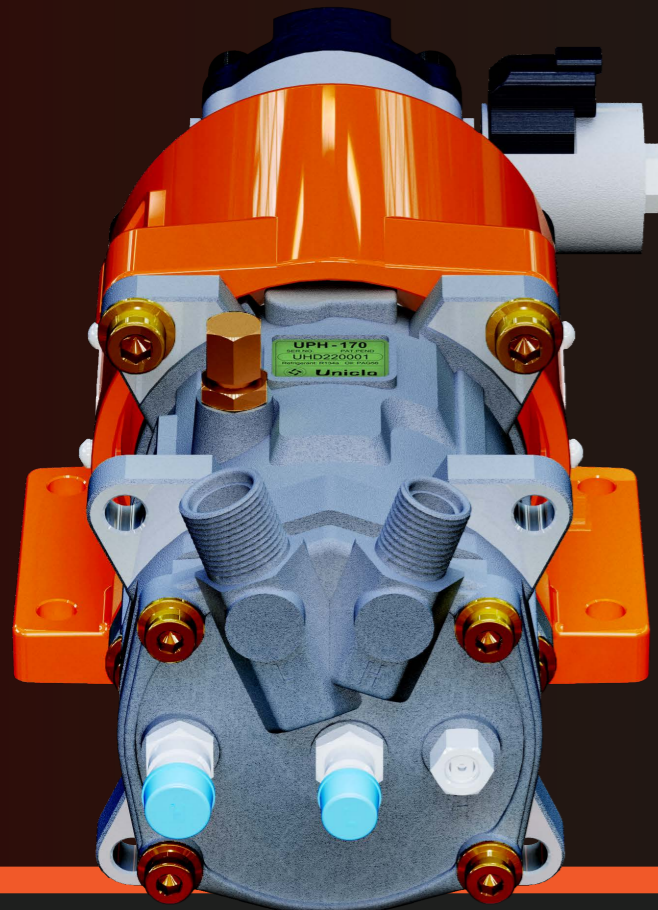

UPH150 & UPH170

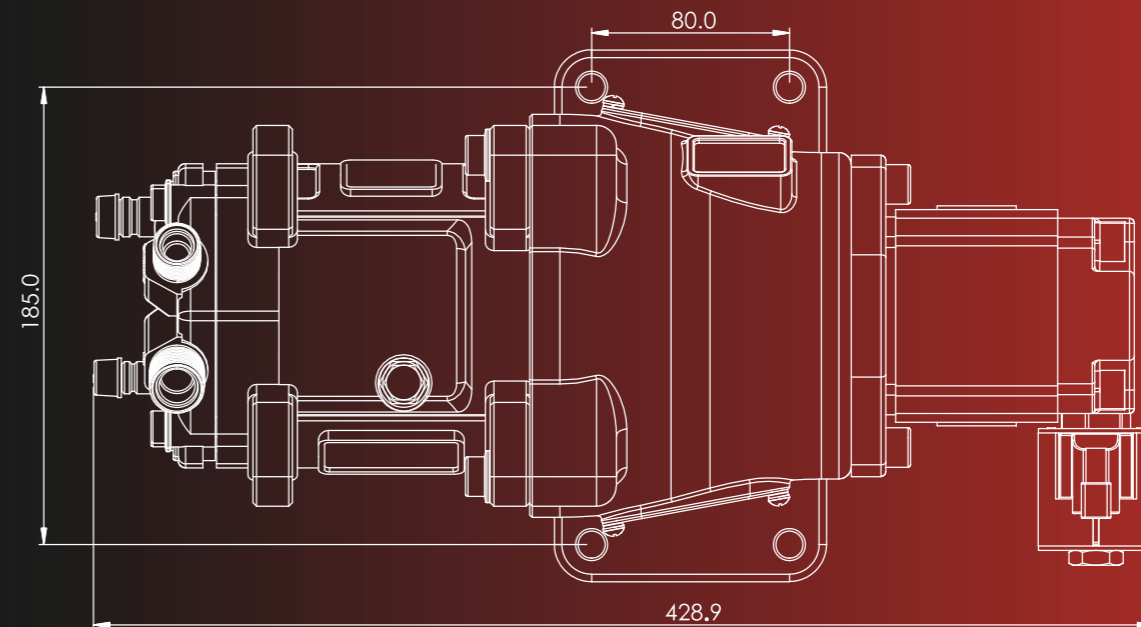
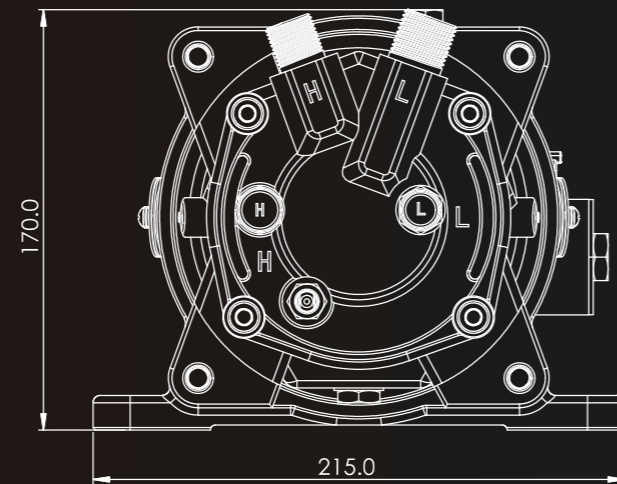

UPH200

Hydraulic Motor

Assembly Schematic

Unicla hDrive Compressor assemblies are supplied fully-assembled, and include a high-performance 14 cc hydraulic motor available with or without solenoid.

Hydraulic Motor Specifications

| | |
|---------------------------------------------------------|-----------------------------------------------------------------------|
| Theoretical Displacement | 14.0 cc/rev (0.85 in ³ /rev) |
| Maximum Continuous Pressure | 250 bar (3625 psi) |
| Speed Range | 800 to 2500 rpm |
| Ideal Speed Range | 1500 to 1850 rpm |
| Rotation when looking towards the end of the driveshaft | Counter-clockwise |
| Operating Temperature Range | Continuous 0°C to 80°C Cold Start -20°C Max. Intermittent 100°C |
| Maximum Shaft Seal / Drain Line Pressure | 5 bar (75 psi) |

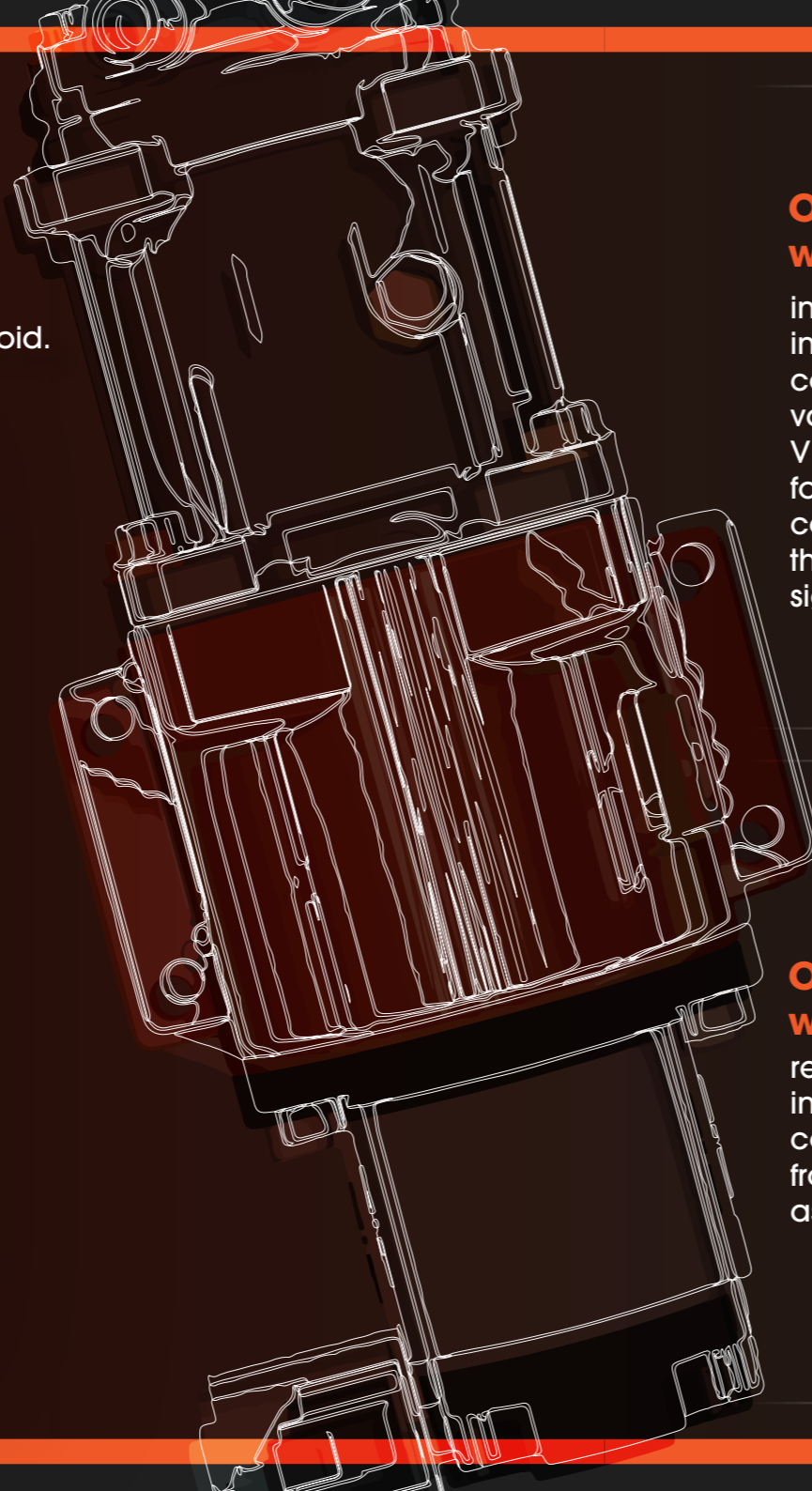

Option 1 with solenoid:

includes an integrated on/off control solenoid valve with 12 or 24 V dc coils, allowing for a direct connection to the thermostat control signal.

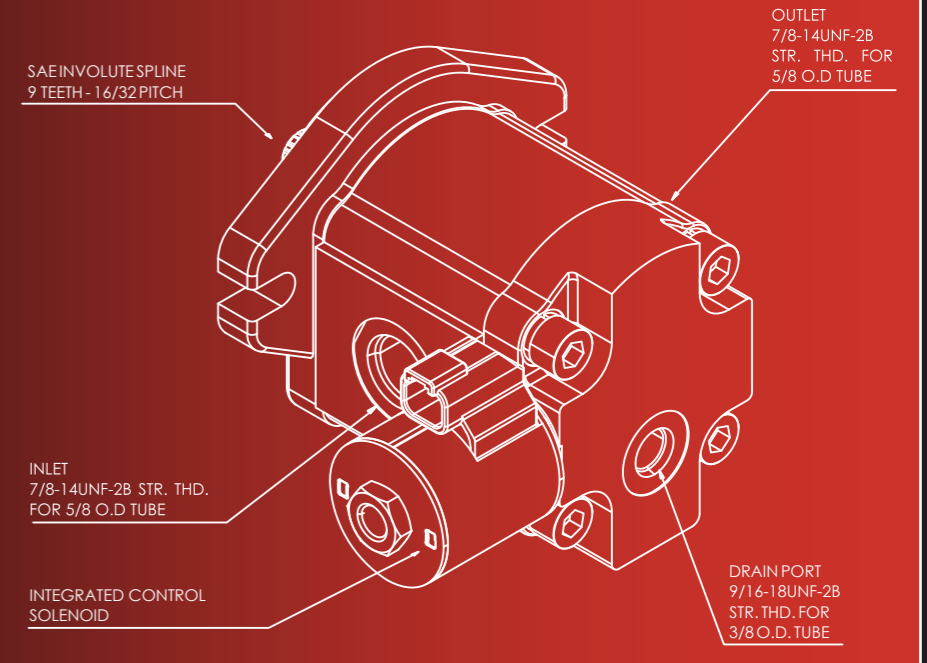

Option 2 without solenoid:

removes the integrated on/off control solenoid from the motor assembly.

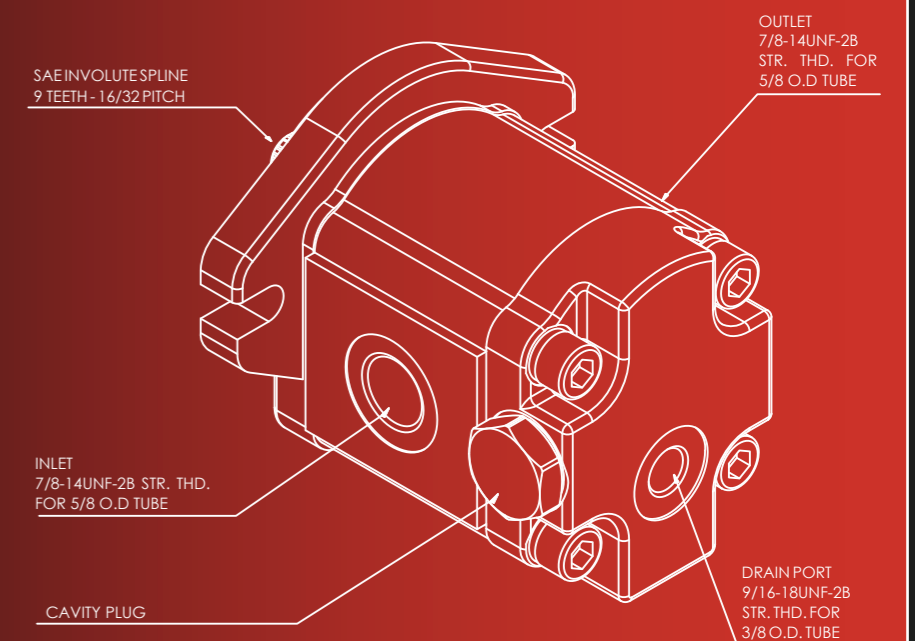



Solenoid coil connector

Solenoid coil plug (V dc)

Unicla hDrive provides full compressor operation even while the asset is at idle.

Hydraulic connection: Hydraulic oil flow is direction-specific.

Note: The motor will not function if flow is reversed.

Port identification: Refer to the flow direction arrow on the motor housing for flow direction confirmation.

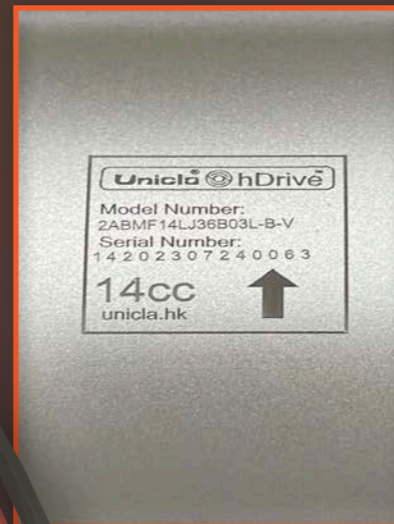

Plug and play. Harness and hydraulics.

Installing the Unicla hDrive compressor assembly couldn't be easier.

Step 1 - Compressor refrigerant hose connection.

- Ensure fitting threads are clean and free from debris
- Use new O-rings
- Torque fittings to specification
- Connection and system commissioning as per standard AC system guidelines

Step 2 - Solenoid coil electrical connection.

- On/Off solenoid coil connects directly to original compressor clutch wire feed
- Confirm the correct solenoid coil operating voltage
- Connect the compressor clutch wire feed DC voltage to the supplied lead harness
- Carefully insert the Deutsch plug into the solenoid connector, noting the alignment of the retention clip
- The presence of DC voltage to the harness allows hydraulic pressure to be supplied to the motor (motor run state)
- The absence of DC voltage allows the hydraulic fluid to flow freely from the inlet to the outlet via the internal bypass valve (motor stopped state)
- Solenoid coil is not polarity dependant

Step 3 - Hydraulic hose connection to hydraulic motor.

- Connect hydraulic inlet
- Connect hydraulic outlet
- Connect hydraulic drain port
- Hydraulic oil flow is directional - the motor will not function if flow direction is reversed

The Ten-Point plan.

Easy assembly, service or repair. Anywhere.

The Unicla GenIII hDrive compressor assembly is designed for easy service and maintenance in the field. Using common hand tools, this Ten-Point plan provides the correct procedure for building a complete assembly from individual components. Ensure the tolerances relating to the coupling are within specification, and the complete assembly will provide long-lasting, reliable service.

1 Coupling Part # C014-8T

- a. Connector A
- b. Connector B

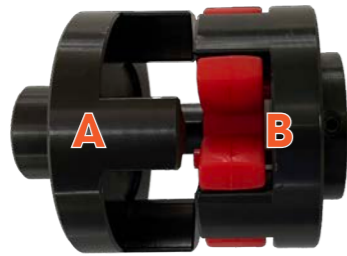

2 Installing coupling connector A

Important: Connector A position on compressor motor shaft may vary due to machining tolerances. Begin by using 4.0 mm shims to achieve a 1.00 mm air gap between connector A and B (Step 8).

You may need to repeat this process.



3 Tighten bolt (M6 x L18) to 14.7 Nm

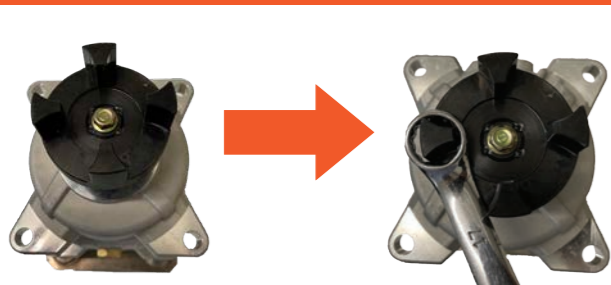

4 Tighten compressor and coupling housing

Fix compressor on top of housing using bolts supplied (4 M10 x L35)



5 Tighten M5 screws on both sides

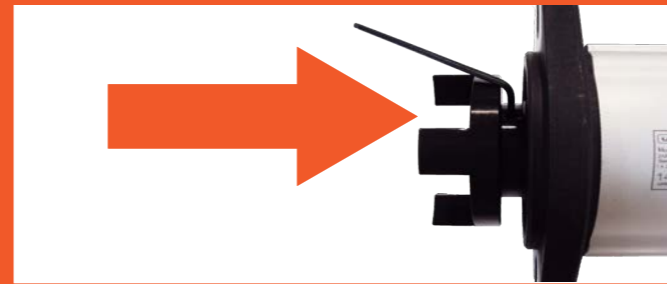

6 Install cushion to connector B

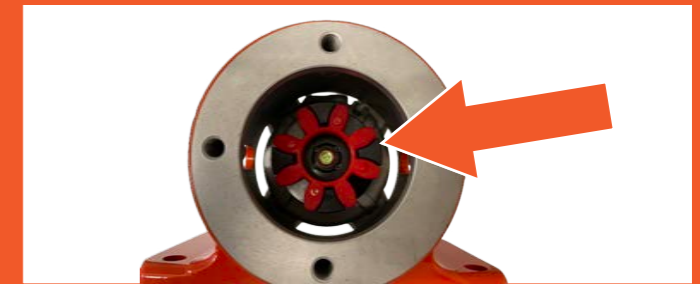

7 Install hydraulic motor to coupler housing using bolts (2 M10 - not supplied)



8 Important: Ensure airgap is 1.00 mm (+/- 0.2 mm) between connector A and B on both sides

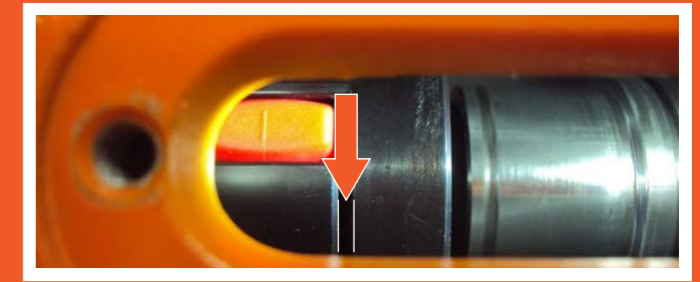

9 Install connection plate

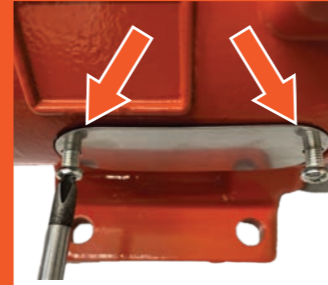

10 Complete assembly



For detailed information and Unicla recommendations on fitting hDrive in special applications, measuring compressor thermal and pressure loads, and calculating extra oil requirements in larger systems, we recommend you visit our website where expert advice from Unicla engineers can be found: www.unicla.hk

The whole family is here.

And every one of them is a hard worker.

Choose the capacity. Choose the motor. Choose the rear cap. Choose the oil.

Choose Unicla hDrive.

The Gen III hDrive family provides a diverse range of compressor assemblies to cater for every conceivable application required by the mining, agricultural, transport, and earth moving industries. Decades of engineering rigour have produced a best-in-class product, validated by exhaustive testing in our world-class environmental test chamber.

No matter the problem, we have the solution. The choice is yours.

| rpm | Hydraulic oil flow rate (LPM) | Compressor Model | Cooling Capacity 0°C EST/ 50°C CST (kW) | Cooling Capacity 5°C EST/ 50°C CST (kW) |
|------|-------------------------------|------------------|-----------------------------------------|-----------------------------------------|
| 1250 | 17.5 | UPH150 | 4.5 | 5.7 |
| | | UPH170 | 5.3 | 6.7 |
| | | UPH200 | 6.1 | 7.8 |
| 1750 | 24.5 | UPH150 | 6.0 | 7.6 |
| | | UPH170 | 7.1 | 9.0 |
| | | UPH200 | 8.2 | 10.5 |
| 2250 | 31.5 | UPH150 | 7.3 | 9.3 |
| | | UPH170 | 8.6 | 11.0 |
| | | UPH200 | 10.0 | 12.8 |



C014-8T
UPH 8T coupling, bolt kit - 150/170/200 series



H014-1517
UPH Orange Housing, bolt kit & plate - 150/170 series

H014-0200
UPH Orange Housing, bolt kit & plate - 200 series



M014-03J12
Unicla Hydraulic Motor 14 cc, 12 V solenoid

M014-03J24
Unicla Hydraulic Motor 14 cc, 24 V solenoid



M014-03JP
Unicla Hydraulic Motor 14 cc, plug w/o solenoid



M014-12V
12 V Coil (2-pin) suit Unicla Hydraulic Motor

M014-24V
24 V Coil (2-pin) suit Unicla Hydraulic Motor



M014-P
Cavity plug (Bypass) suit Unicla Hydraulic Motor 14 cc



M014-SH
Coil harness (1 m) suit M014 Coils (2-pin)

Unicla®  **hDrive**™

 **GEN III**

**The best hydraulic drive
just got better. Again.**

HEAD OFFICE

Unicla International Limited
Unit 1109, 11/F, Manhattan Centre,
8 Kwai Cheong Road,
Kwai Chung, N.T., Hong Kong
PHONE: +852 2422 0180
FAX: +852 2422 0680
EMAIL: sales@unicla.hk
www.unicla.hk

Unicla Australia

14 Motorway Circuit Ormeau,
Queensland 4208 Australia
PHONE: +61 7 5549 4033
FAX: +61 7 5549 4044
EMAIL: sales@unicla.hk
www.unicla.hk